

# Max-Tek Super Abrasive Machining Systems

## Nozzle Segments

- Radial Forms
- Radial Surfaces
- Radial Grooves
- Slots

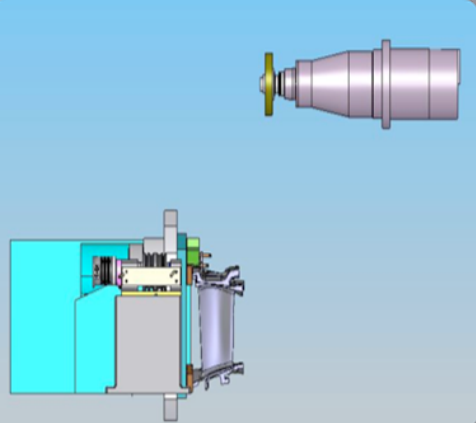
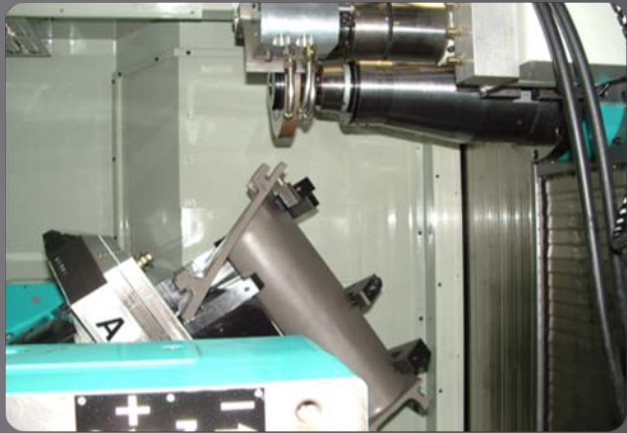

$X = 0''$   
 $Z = 0''$   
 $Y = 0''$   
 $A = 90^\circ$   
 $C = 0^\circ$

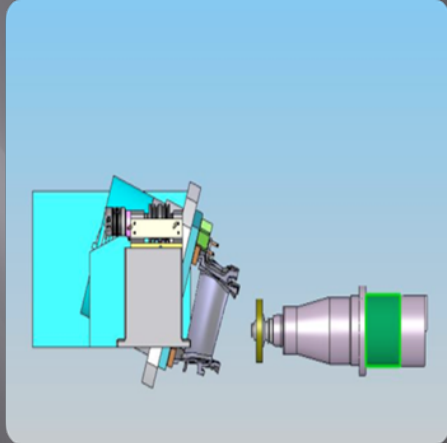

$X = 0''$   
 $Z = 0''$   
 $Y = 47.2''$   
 $A = 110^\circ$   
 $C = 0^\circ$



100 HP or more - 100 Hsk spindle  
 2,500 - 12,500 RPM Spindle  
 800 mm Trunion Table

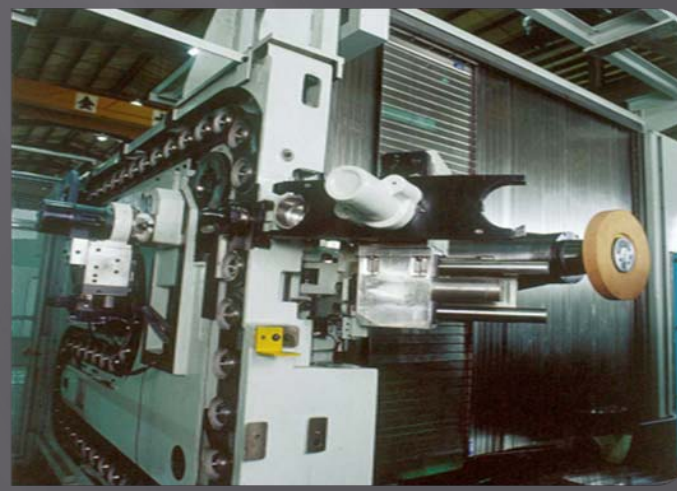

Nozzle Changer and  
 Automatic Wheel Changer